

II 2G c IIB T3 (II 3G c IIB T3)

BA-CFB-RZR-RER-ATEX 6.5 - 10/2015

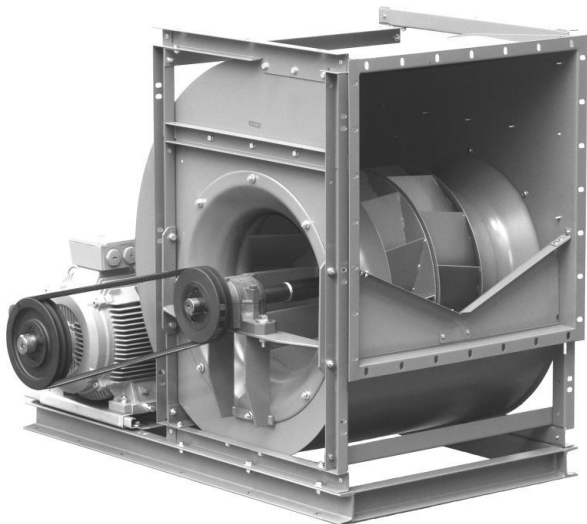

RZR

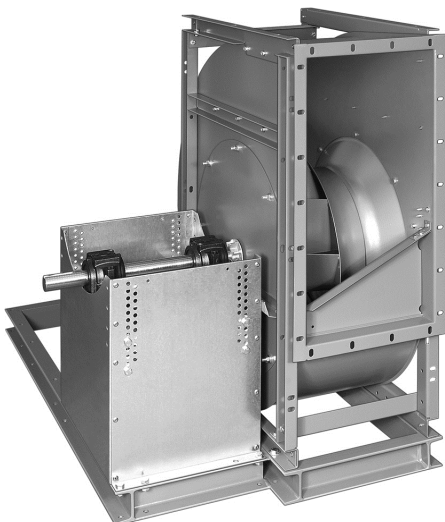

RER

# Contents

1. Revision Index.....	EN-2
2. About This Operating Manual .....	EN-3
3. Designated Use.....	EN-5
4. Safety .....	EN-7
5. Product Description.....	EN-11
6. Handling and Storage.....	EN-14
7. Installation .....	EN-15
8. Electrical Connection.....	EN-18
9. Commissioning.....	EN-20
10. Maintenance.....	EN-21
11. Disturbances .....	EN-25
12. Service, Spare Parts and Accessories.....	EN-26
13. Annex .....	EN-26
EU Declaration of Conformity to EU Council Directive 2014/34/EU (ATEX).....	EN-30
EC-Declaration of Incorporation .....	EN-31

English

EN-2...EN-31

Further languages on request.

## 1. Revision Index

<i>Tabelle 1-1: Revision Index</i>	
<b>Revision</b>	<b>Date</b>
BA-RV 6.1 – 08/2011	08/2011
BA-CFB-RZR-RER-ATEX 6.2	01/2014
BA-CFB-RZR-RER-ATEX 6.3	07/2014
BA-CFB-RZR-RER-ATEX 6.4	03/2015
BA-CFB-RZR-RER-ATEX 6.5 - 10/2015	05/2015

## 2. About This Operating Manual

These operating instructions are an integral part of the centrifugal fan. Nicotra Gebhardt GmbH shall not accept any liability or provide any warranty cover for primary damage or secondary damage arising as a consequence of disregarding these operating instructions.



- ▶ Read operating manual carefully before use.
- ▶ Retain operating manual for entire service life of centrifugal fan.
- ▶ Keep operating manual accessible to personnel at all times.
- ▶ Pass operating manual on to any subsequent owner or user of centrifugal fan.
- ▶ Insert any supplementary instructions received from the manufacturer in the operating manual.

---

### 2.1. Validity

This operating manual only applies to the centrifugal fans stated on the front page.

---

### 2.2. Target Group

This operating manual is intended for operators and qualified professionals trained in installation, commissioning, operation, maintenance and decommissioning.

---

### 2.3. Other Applicable Documents

- ▶ **In addition to the operating instructions, to the type plate, warning and indication signs – fixed to the fan – the following documents have to be observed:**

- |                    |                           |
|--------------------|---------------------------|
| - DIN VDE 0100-100 | - EN 13463-1; -5          |
| - EN 60204-1       | - EN 1127-1               |
| - EN ISO 13857     | - EN 60079-0              |
| - EN ISO 12100     | - EN 14986                |
| - EN ISO 13732-1   | - Technical Catalogue     |
|                    | - EU-Directive 2014/34/EU |

---

### 2.4. Symbols and Markings

#### 2.4.1. Use of Warning Signs





Signal Word

Nature, source and consequences of hazard!

- ▶ Steps required to avert danger

### 2.4.2. Levels of Danger in Warning Signs

Table 2-1: Levels of danger in warning signs

Symbol / Danger Level	Likelihood of Occurrence	Consequences of Neglect
 <p style="text-align: center;"><b>Danger</b></p>	Imminent danger	Death, serious physical injury
 <p style="text-align: center;"><b>Warning</b></p>	Potential danger	Death, serious physical injury
 <p style="text-align: center;"><b>Caution</b></p>	Potential danger	Minor physical injury
<b>Caution</b>	Potential danger	Damage to property

### 2.4.3. Notes

**Note** Note giving pointers for easier or safe work.  
 ► Steps required for easier or safe work.

### 2.4.4. Other Symbols and Markings

Table 2-2: Other symbols and markings

Symbol	Meaning
☑	Requirement for an operation
►	Operation with one step
1. .... 2. .... 3. ....	Operation with several steps
•	Bullet point (primary list)
-	Bullet point (secondary list)
<b>Accentuation (bold)</b>	For emphasis

### 3. Designated Use

#### 3.1. Operating Data / Maximum Ratings



Caution

**Risk of injury!**

- ▶ Adhere to technical specifications and permissible limits.

**For technical specifications reference should be made to the type plate, technical data sheet and technical catalogue!**

**To be observed specially!**

- specified motor rating
- smallest permitted pulley diameter
- maximum fan speed [rpm]
- permissible kind of the medium
- permissible medium temperature

**Note ATEX category II 2G IIB T3 or II 3G IIB T3**

Fans of this category are designed for areas where an explosive atmosphere – as a mix of air, gases, vapours or mist - is likely to occur occasionally (2G) or rarely (3G).

The unit related measures for explosion protection of this category have to offer the necessary amount of safety, even in the case of frequent unit troubles or failure modes, to be usually anticipated (predictable troubles).

For the operation of the fans in explosion hazardous areas the relevant prescriptions, local regulations and directives (ATEX 2014/34/EU) for manufacturers and user have to be respected.

**Permissible conveyed medium temperatures:**

*Table 3-1: Maximum ratings*

Range ATEX	perm. temperature of conveyed medium	max. ambient temp. on drive motor
RZR	-20°C to +40°C (+60°C)	+ 40°C (60°C)
RER	-20°C to +60°C	

The temperature range in special cases can be extended to this value if the coolant temperature is + 60 ° C! (Possibly taking into account a power reduction according to the manufacturer)

**Examples of incorrect use include the following:**

- Extraction of media with impermissibly high or low temperatures
- Extraction of corrosive media
- Extraction of very dusty media

**The results are:**

- Bearings damage
- Corrosion damage
- Unbalancing
- Vibration
- Deformation
- Abrasion damage

**Caution Unauthorised operation**

- No operation above the indicated rpm (see type plate, data sheet)
- No operation at rpm ranges with increased vibration (resonance)
- No operation at rpm ranges out of permitted fan curve area (stability of flow pattern)
- No operation if fan becomes polluted



Caution

**Danger points:**

**There can be injury to personnel and material damage through impeller breakage, shaft breakage, fatigue failure, fire from spark creation.**

**3.2. Explosion Protection Markings**

The marking on the type label of the explosion proof fans includes the group, category, ignition class and temperature class as well as a CE-Ex-sign thus confirming the conformity to the European directive 2014/34/EU.

The manufacturer's declaration and the declaration of conformity 2014/34/EU (ATEX) are attached to this maintenance instructions.

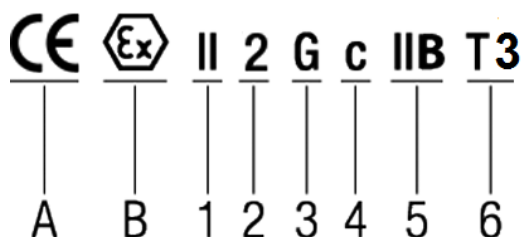

Fig 3-1: Explosion protection markings (example)

<b>A</b>	<b>CE-Mark</b>
<b>B</b>	<b>Hazardous duty marking</b>
<b>1</b>	<b>Machine group II</b> Non-electric machines for use outside of the mining industry and underground mining
<b>2</b>	<b>Machine category 2</b> (internal and external) for use in Zones 1+2; An explosive atmosphere is only present in the area occasionally
<b>3</b>	<b>Conveyed medium G</b> = Gaseous conveying medium
<b>4</b>	<b>Ignition protection c</b> = Explosion protection through design safety
<b>5</b>	<b>Explosion group IIB</b> = Type of gaseous atmosphere
<b>6</b>	<b>Temperature class T3</b> = max. temperature on machine surface +200°C

## 4. Safety

### 4.1. Product safety

The fans offer a high degree of operational safety and high quality standards guaranteed by a certified Quality Management System (EN ISO 9001).

Before leaving the factory all the fans are inspected and sealed with a mark of conformity.

Nevertheless, when operating fans supplied by Nicotra Gebhardt GmbH there can be a risk of death or injury for the user or third parties, and a risk of damage to the fan or other material assets.

- Only use the fans in perfect working order and for its designated use as intended, having due regard for safety, an awareness of hazards and in due compliance with the operating instructions.
- Arrange immediate repair of any faults which could compromise safety.



**Danger**

---

**Potentially explosive gas mixtures in conjunction with hot and moving parts may cause serious or fatal injury.**

**Risk of explosion due to increased ambient temperature!**

- ▶ **Observe ambient temperature**
- ▶ **Ensure adequate supply of cooling air**

---

### 4.2. Safety Instructions

The fan may only be commissioned, operated and serviced in compliance with the following instructions:

- Operating instructions
- Warning and information signs on the fan
- Any other operating and installation instructions pertaining to the machine
- Terms and requirements relevant to the machine
- Applicable national and regional regulations, especially regarding explosion protection, health & safety and accident prevention.

### 4.3. Safety Instructions

1. Use appropriate safeguards to prevent contact with rotating parts (shafts, impeller, etc.).
2. Protection devices are so selected so that sucking or falling-in of objects will be prevented.
3. After installation (and before electrical connection) immediately refit any guards which have been removed during installation.



**Danger**

The fans are delivered without inlet- and discharge guards. If there is a danger of contact with the impeller owing to the way the fan is installed, then it is necessary to fit guards conforming to EN ISO 13857 (available as an accessory).

Only then can the fan be set in operation!



**Danger**

ATEX fans of categories 2G or 3G are made for integration into installations. Care must be taken to avoid any ingress of object into the fan. (min. IP20 to EN 60529).

The user has to find corresponding protection in order to ensure a safe operation!



**Caution!**

The suitability of protection devices and their fixtures to the fan have to be evaluated within the overall security concept of the installation.

### 4.4. Professional Staff

1. Ensure that the Installation of the fan and any work on it is carried out by skilled professionals only with due regard to these operating instructions and any applicable regulations.
2. Electrical connection to be carried out by qualified electricians only.

### 4.5. Protective Gear



**Caution!**

Ensure that members of staff are wearing protective gear appropriate to their deployment and environment.

The protective clothing is specified below!

### 4.6. Specific Hazards

#### 4.6.1. Noise Emission

The sound emission expected during normal use of the fan is documented in the technical lists and should be duly taken into account.



- ▶ **Wear ear defenders when working near to or on the running fan!**



#### 4.6.2. Heavy Loads



The heavy weight of the fan and its components entail the following risks in transit and during installation:

- Risk of being trapped, crushed or cut by moving or toppling machinery
- Danger of falling components

- ▶ **Do not stand or work under suspended loads.**  
**Wear a hard hat, safety shoes and gloves.**

#### 4.6.3. Rotating Shafts and Impellers



Objects falling onto rotating shafts and impellers can fly off at an angle and cause serious injury.

Articles of clothing and hair can get caught in rotating shafts and impellers.

- ▶ **Do not remove guards during operation.**
- ▶ **Do not wear loose-fitting clothing when working near rotating shafts and impellers**  
**Wear goggles**

#### 4.6.4. Hot Surfaces



There is a risk of sustaining burns or scalds on hot surfaces during operation.

- ▶ **Do not touch the motor during operation.**
- ▶ **When the fan has stopped wait until the motor has cooled down.**  
**Wear protective gloves**

---

### 4.7. Structural Modifications, Spare Parts

**Notes** Unauthorised structural modifications may not be made to the centrifugal fan without the consent of Nicotra Gebhardt GmbH. Nicotra Gebhardt GmbH shall not accept liability for any damage arising as a result of said modifications.  
Use only genuine spare parts supplied by Nicotra Gebhardt GmbH.

**Caution** In areas subject to explosion hazards the fan may only be modified or converted by Nicotra Gebhardt GmbH itself, by a service location approved by the company, or by personnel authorised and trained by the company.

---

### 4.8. Installation and Maintenance

The following steps should be taken before working on the fan:

1. Ensure that the atmosphere is not potentially explosive.
2. Switch off the machine and take measures to prevent it from being switched back on accidentally.
3. Display the following message on a sign:  
**Do not switch on! Work currently in progress on the machine**

### 4.9. Signs on the Fan

Depending on the model, the type plate and the arrow indicating the direction of rotation are fitted to the housing or handle for high visibility.

#### 4.9.1. Type Plate

Fig. 4-1:  
Example type plate

<b>NICOTRA Gebhardt</b> D-74638 Waldenburg Tel.: +49 (0) 7942 101 384 Fax.: 385 email: service@gebhardt.de <b>RZR 13-1000-2G LG/90</b>			
GERÄTE-NR.	134-369947-152091/1	HERSTELLJAHR	2010
VENTILATOR		MOTOR	
V	= 78920 m <sup>3</sup> /h	U N	= 400/690 V
dPfa	= 1325		Hz
dPt	= 1503		Hz
n	= 1051		/56 A
n max	= 1217 l/min	n N	= 1480 l/min
Pw	= 40 kW	P N	= 55,00 kW
Pw max	= 68 kW	P N max	= 75 kW
Dichte	= 1.2 kg/m <sup>3</sup>	Schutzart	IP 55
Tmax	= 60 °C	Wärmeklasse	F
		Stromart	3~
 II 2G c IIB T3 (innen/aussen)			

#### 4.9.2 Belt drive plate

Fig. 4-2:  
Belt drive - Sample

<b>Nicotra Gebhardt</b> D-74638 Waldenburg Tel.: +49 (0) 7942 101 384	
Keilriemenantrieb/ Belt drive	
Ventilator/ Fan	RZR 11-0500 LG/90
Nummer/ No.	658/1
Scheibe/ Pulley	140
Buchse/ Bush	1610/38
Motor	
Scheibe/ Pulley	1 SPA 160
Buchse/ Bush	1610/38
Keilriemen/ Belt	XPA 1700 QP
Spannvorschrift/ Tensioning of belt	
Prüfkraft/ Test force in N:	21
Eindrücktiefe/	
Deflection under test force (mm):	6,1
Frequenz/ Frequency in Hz:	48

#### 4.9.3 Arrow Indicating Direction of Rotation

Fig. 4-3:  
Arrow indicating direction of rotation

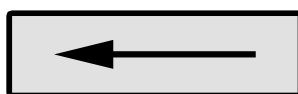

## 5. Product Description

### 5.1. Centrifugal Fans in General

The centrifugal fans can be completed to a fan set by equipping them with base frame and belt drive or acc. to the type & size with pick-a-back and belt drive.

Further options and accessories see proSELECTA II, Technical documentation and price lists.

Examples see subsequent drawings.

---

### 5.2. Centrifugal Fans

The centrifugal fan RZR and RER do meet the requirements of ATEX regulation 2014/34/EU by its safe design and controlled production procedures corresponding to EN 14986 and EN 13463-1/-5.

Classification is made – according to the corresponding type plate – to group II, category 2G, explosion group IIB and temperature class T3.

The centrifugal fans can be supplied completed as a fan set with base frame or pick-a-back, belt drive, and motor.

If the fan is supplied by **Nicotra Gebhardt** as a bare fan i.e. without the necessary accessories, the ATEX conformity is limited to the fan itself as supplied.

The ATEX fan or the fan set supplied by **Nicotra Gebhardt** must not be modified by the customer. Any modification will make the ATEX conformity invalid.

**Materials:**

- **Impeller** made of sheet steel, with ATEX special coating
- **Inlet cone** made of copper

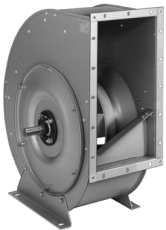
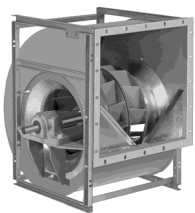

---

**Caution** If the fan installed outside a building or when conveying humid air a condense water drain – available as an accessory – has to be fitted at the lowest point of the casing.

---

**Note** The ATEX fan must not be modified by the user. Any modification will render ATEX conformity invalid.

---

**5.2.1 e.g. RZR 11-**

- 1 Centrifugal fan**
- 2 Base frame with**
- Motor rails -or
- Motor slide bases
- 3 Pick-a-Back**
- 4 Drive**
- 7 Anti-vibration mounts**

**Important Accessories:**

- 5 Access door**  
(if the impeller isn't accessible)
- 6 Drain plug**
- 8 Inlet guard**
- 9 Discharge guard**
- 10 Drive guard**
- 11 Shaft guard**

Contact protection.  
EN ISO 13857

Protection against the  
penetration of articles  
EN 60529

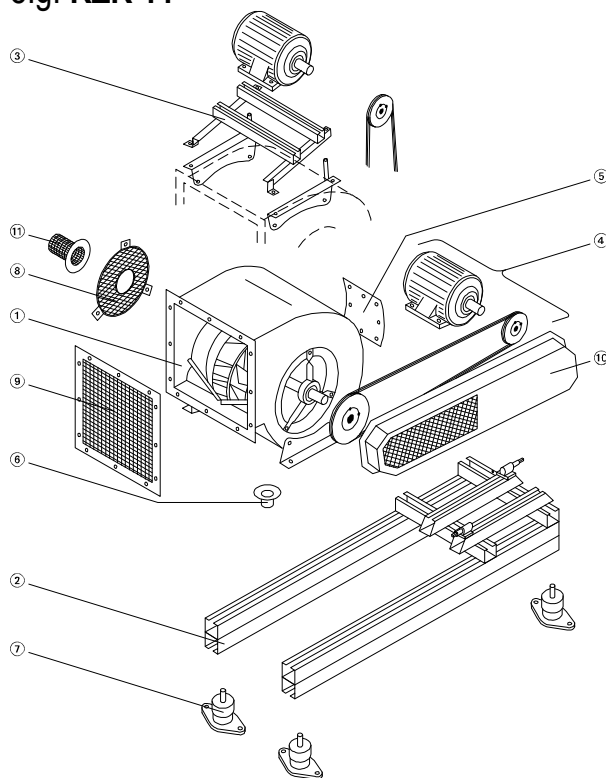

*Fig. 5-1: Fan Set RZR 11*

**5.2.2 e.g. RER 11-**

- 1 Centrifugal fan**
- 2 Base frame with**  
- Motor rails -or  
- Motor slide bases
- 3 Pick-a-Back**
- 4 Belt drive**
- 7 Anti-vibration mounts**

**Important Accessories:**

- 5 Access door**
- ATEX- Scope of supply**
- 6 Drain plug**
- 8 Inlet guard**
- 9 Discharge guard**
- 10 Drive guard**

Contact protection.  
EN ISO 13857

Protection against the  
penetration of articles  
EN 60529

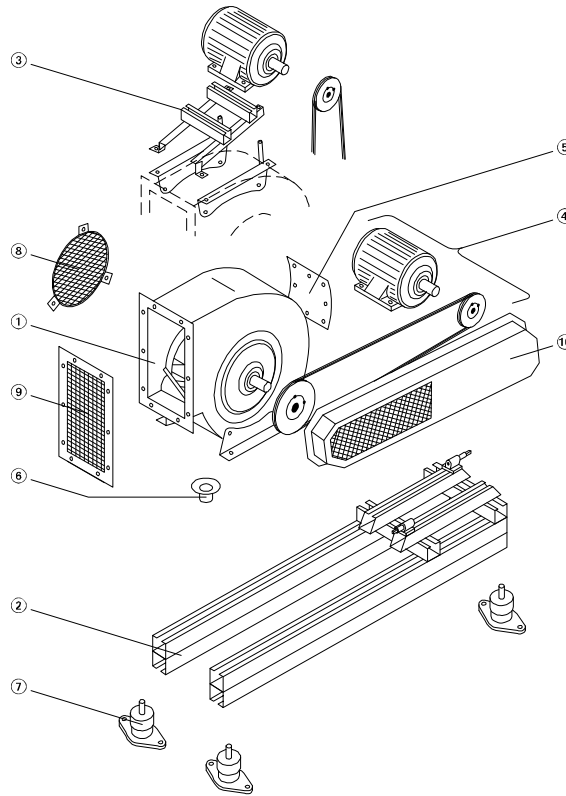

*Fig. 5-2: Fan Set RER 11*

**5.3.3 e.g. RER 13 -**

- 1 Centrifugal fan with**  
base frame
- 2 Motor rails –or**  
- Motor slide bases
- 3 Motor**
- 4 Belt drive**
- 7 Anti-vibration mounts**

**Important Accessories:**

- 5 Access door**
- ATEX- Scope of supply**
- 6 Drain plug**
- 8 Inlet guard**
- 9 Discharge guard**
- 10 Drive guard**

Contact protection.  
EN ISO 13857

Protection against the  
penetration of articles  
EN 60529

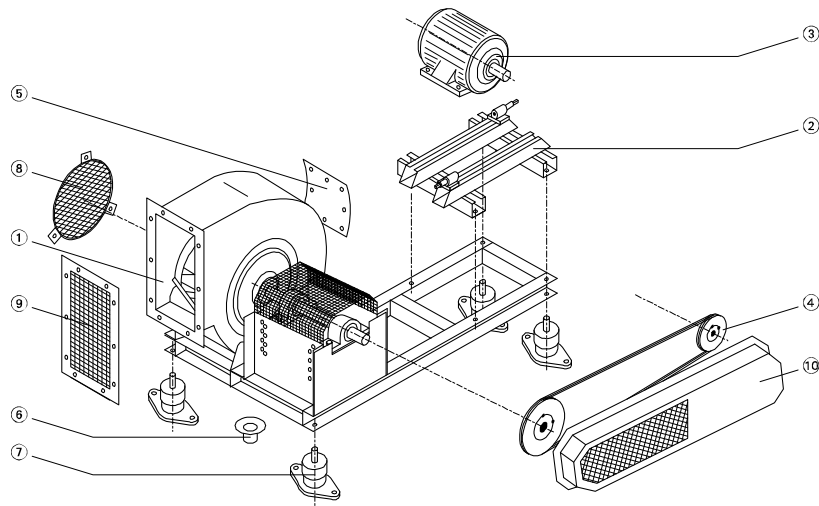

*Fig. 5-3: Fan Set RER 13 / 17*

## 6. Handling and Storage



### 6.1. Packing

Centrifugal fans are packaged in sturdy cardboard boxes or on wooden crates depending on their size and weight. Instructions on removing transportation locks are enclosed.

### 6.2. Symbols on Packing

The following symbols are printed on the cardboard boxes:

Table 7-1: Symbols on packaging

Symbol	Meaning
	Handle with care
	Keep dry
	Top

### 6.3. Handling of Centrifugal Fans



#### Danger of injury from falling components!

- ▶ Do use only certified lifting devices suitable for the fans to handle!
- ▶ Select the transportation mode according to the weight and execution of the fan!
- ▶ Handle the fan as long time as possible with its original packing!
- ▶ Secure load!
- ▶ Do not stand under suspended loads!

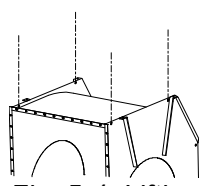

Fig. 5-4: Lifting lugs

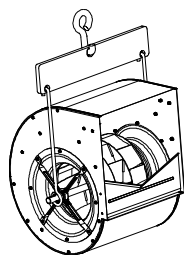

Fig. 5-5: Lifting beam

1. Select the transportation mode according to the weight, execution, or suspension possibilities of the fan  
**(Weight data see technical catalogue).**
2. Centrifugal fans to be attached at the lifting lugs provided or at the base frame, base plate, or supporting plate.
3. If necessary and possible screw in a shackle.
4. Fans without a frame to be handled by using special lifting device taking the fan at both shaft ends and to be transported in a horizontal shaft position only!
5. When using transport belts always provide 4 points of suspension (2 belts).  
The belt may not exert a deforming force to the fan or its packing. If necessary use a spacer!
6. Secure load with belts or fix it against sliding!
7. Handle centrifugal fan with care to prevent damages, avoid e.g. shock or rough placement.

**Caution** These are **NO** fixing points at the fan!

- Bearing struts
- Casing flange / Casing frame
- One-sided fixing at fan shaft
- Motor lifting lug

## 6.4. Storage of Centrifugal Fan

**Caution** Risk of corrosion!

- ▶ Store the fan in its packaging, adding any other protection dictated by its storage environment.
- ▶ Store centrifugal fan in a well-ventilated room only at normal temperatures and in a non-corrosive atmosphere.
- ▶ Store centrifugal fan in conditions registering less than 70 % atmospheric humidity.
- ▶ Adhere to max. permissible temperature of  $-20\text{ °C}$  to  $+40\text{ °C}$ .

## 7. Installation

### 7.1. Safety Instructions for Installation

- ▶ Observe the safety instructions and preventive measures in Chapter 4 and the relevant legal requirements.

**Caution** The fan system supplied by Nicotra Gebhardt must not be modified in any way!  
It's operation is exclusively permitted in it's state as originally supplied and within the LIMITS SPECIFIED.  
(Respect catalogue- and type plate data).

### 7.2. Preparation to Installation

- Place of installation suitable for the centrifugal fan in terms of its category, condition, ambient temperature and environmental media.
- The installation surface is plane and able to support the weight.

1. Unpack centrifugal fan carefully.
2. Unfasten or dismantle transport locks
3. Packing material to be fully removed and disposed.

### 7.3. Carrying out Installation

1. The fan or base frame must be fixed without stressing to the supporting structure.
  2. AVM to be regularly placed around centre of gravity and definitely fixed. Check whether the AVM is evenly under load.
- No forces or vibrations may be transferred from other plant parts to the fan (flexible connection).
  - The flexible connections (ATEX) at intake and/or discharge are installed well aligned and freely moving.
  - The AVM are freely moving and under even load!
  - The impeller is turning idly and does not touch at intake cone!
  - The stability against collapse of the fan has been checked.

Conveying humid air outside installation:

- Is a condense water drain fitted to the lowest point of the casing

### 7.4. Checking the Gap Dimension on the Fan

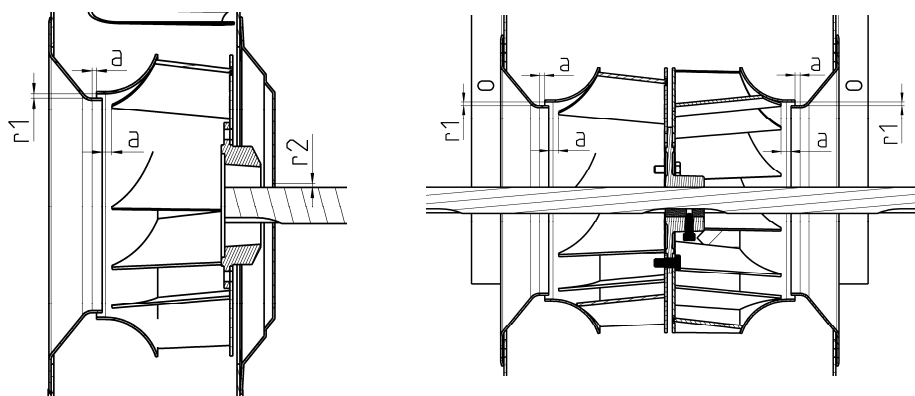

Table 7-1: Gap width RER

Table 7-2: Gap width RZR

**Check gap between impeller and inlet cone and between shaft and drilling in the cover disk (RER) against chart values below!**

For ATEX fans the rule is applied that at critical spots where sparks can be ignited by friction, certain gaps have to be respected.

With the RZR and RER fans this critical spots are between intake cone and rotating impeller and if existing at the shaft passage at the casing.



RER	r1	a	r2
	mm	mm	
RER 0200-2G / -3G	2,0	2,0	2,0
RER 0225-2G / -3G	2,0	2,0	2,0
RER 0250-2G / -3G	2,0	2,0	2,0
RER 0280-2G / -3G	2,2	2,2	2,0
RER 0315-2G / -3G	2,4	2,4	2,0
RER 0355-2G / -3G	2,7	2,7	2,0
RER 0400-2G / -3G	3,0	3,0	2,0
RER 0450-2G / -3G	3,4	3,4	2,0
RER 0500-2G / -3G	3,8	3,8	2,0
RER 0560-2G / -3G	4,3	4,3	2,0
RER 0630-2G / -3G	4,8	4,8	2,0
RER 0710-2G / -3G	5,4	5,4	2,0
RER 0800-2G / -3G	6,0	6,0	2,0
RER 0900-2G / -3G	6,7	6,7	2,0
RER 1000-2G / -3G	7,6	7,6	2,0

RZR	r1	a	
RZR 0200-2G / -3G	2,0	2,0	
RZR 0225-2G / -3G	2,0	2,0	
RZR 0250-2G / -3G	2,0	2,0	
RZR 0280-2G / -3G	2,2	2,2	
RZR 0315-2G / -3G	2,4	2,4	
RZR 0355-2G / -3G	2,7	2,7	
RZR 0400-2G / -3G	3,0	3,0	
RZR 0450-2G / -3G	3,4	3,4	
RZR 0500-2G / -3G	3,8	3,8	
RZR 0560-2G / -3G	4,3	4,3	
RZR 0630-2G / -3G	4,8	4,8	
RZR 0710-2G / -3G	5,4	5,4	
RZR 0800-2G / -3G	6,0	6,0	
RZR 0900-2G / -3G	6,7	6,7	
RZR 1000-2G / -3G	7,6	7,6	
RZR 1120-2G / -3G	8,5	8,5	
RZR 1250-2G / -3G	9,5	9,5	
RZR 1400-2G / -3G	10,6	10,6	
RZR 1600-2G / -3G	12,1	12,1	

1. Measure the gap and ensure that the width of the gap does not fall below the threshold in any phase of the rotation (manual rotation).
2. Carry out measurements on four 90° points on the circumference.

## 7.5. Install Protection Devices

1. Fit guards to protect exposed inlet openings (EN ISO 13857).
2. Design safety devices in such a way that they prevent objects from being sucked in or from falling in (see EN 60529).

## 8. Electrical Connection

### 8.1. Safety Instructions for Electrical Connection



**Danger**

#### **Danger of electric shock!**

- ▶ Observe the safety instructions and preventive measures in Chapter 4 as well as the relevant legal requirements.
- ▶ EN 60204-1, DIN VDE 0100-100; EN 60079-0, VDE 0170-1 EN 60079-14, VDE 0165-1

All the fans are delivered ready for connection.  
The terminal box is easily accessible.  
The wiring diagram is in the terminal box.

#### **Caution Inspection switches, electronic control units and frequency converters can cause material damage!**

- ▶ Do not use electronic control units or frequency converters in areas subject to explosion hazards.
- ▶ Install inspection switches - except inspection switches approved for areas subject to explosion hazard – outside the area subject to explosion hazards.

#### **Caution Excessive te-time can cause material damage!**

- ▶ When using overload protective devices do not exceed the te-time stated on the motor rating plate.

**Note** The standard motors are classified as protection category “Increased Safety Ex e II”, temperature class T1 to T3, and insulation class B in accordance with Directive 2014/34/EU (ATEX) and IEC/EN 60079-0, IEC/EN 60079-7.

- Current, voltage and frequency of mains supply checked for conformity with fan type plate and motor rating plate.
- Star-delta or soft start provided for motors with a nominal output >4 kW.
- Adhere to the output limits imposed by the power supply company.
- If necessary, an Isolator must be provided(outside the area subject to explosion hazards)
- All components are provided with an earthing. The fan components are electrically connected to each other.
- The fan is protected against unexpected start!**
- Chapter 4. „Safety“must be respected!**

## 8.2. Electrical connection of the motor

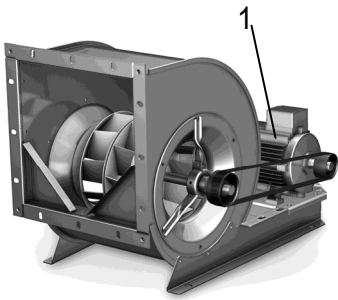

Fig. 8-2: Fan set (without protection guard)

1. Fit inspection switch if applicable.
2. Connect feed line to fan or service switch.
3. Connect motor as shown on connection diagram supplied.
4. Ensure that all the electrical safety devices have been fitted and connected.

1 = Connection box

---

## 8.3. Motor Protection

- Protect motors against overload in accordance with EN 60204-1.
- Only motors conforming to the corresponding ATEX – category of the fan are permitted.
- Motor protection switches must be set to the nominal motor current (see type plate). A higher setting value is not admitted!
- Respect the te–time for overload protection indicated on the motor type plate.

---

**Caution** Fuses or circuit breakers do not provide sufficient motor protection. Damage due to insufficient motor protection invalidates the manufacturer's guarantee.

---

**Note** In all cases the power limitations provided by the existing power supply company must be taken into account.

If plant conditions necessitate a direct start the suitability of the fan design must be confirmed with Nicotra Gebhardt. Fans with high inertia impellers can take over 6 seconds to reach top running speed. In these cases heavy duty motor protection relays or bimetal relays must be provided.

---

## 8.4. Carrying out a Test Run



**Danger**

Risk of injury from rotating impeller!

- ▶ Never reach into the impeller when the fan is open.

1. Take measures to prevent the centrifugal fan from being switched on accidentally
2. Clear the ducting system and fan of all foreign bodies (tools, small parts, construction waste, etc.
3. Close all the inspection openings.
4. Switch on the fan and check the direction of rotation of the impeller by comparing it with the arrow on the fan indicating the direction of rotation.
5. If the direction of rotation is wrong, reverse the polarity of the motor having due regard to the safety instructions.
6. Once operating speed has been reached measure the current consumption and compare it with the nominal motor current on the fan type plate or motor rating plate
7. If there is continuous overload switch the fan off immediately.
8. Check that the fan runs smoothly and quietly. Ensure that there are no unusual oscillations or vibrations.
9. Check the motor for any abnormal noises.

---

## 9. Commissioning

The motors are designed for continuous operation S1. If operations involve more than three starts per hour Nicotra Gebhardt GmbH shall be required to confirm the suitability of the motor.

---

**Potentially explosive gas mixtures in conjunction with hot and moving parts may cause serious or fatal injury.**



**Danger**

**Risk of explosion due to increased ambient temperature!**

- ▶ Observe ambient temperature
  - ▶ Ensure adequate supply of cooling air
- 

### 9.1. Conditions for Commissioning in Ex-Area

The following requirements must be met before operating the fan in areas subject to explosion hazards:

- Specifications on the type plate to meet the standards required in the local operating conditions in respect of explosion hazards (machine group, explosion hazard category, explosion hazard zone, temperature class).
- All the components connected to the fan carrying a risk of ignition or explosion to have the required approval certificates.
- The ambient temperature during subsequent use to be within in the allowed limits!

- All the requisite safety devices to be installed.
  - Prevent impeller from contact and from being hit by falling or sucked-in objects.
  - The fan is not operated in a dusty environment.
- Ensure that unacceptable levels of dust are not allowed to gather on the fan.

## 9.2. Commissioning the Centrifugal Fan



**Danger**

### Risk of injury from rotating parts and hot surfaces!

1. Ensure that all the safety devices are fitted.
2. Ensure that the impeller has been secured acc. to EN ISO 13857!

### Action

1. Check the working order of all the connected control instruments.
2. **Switch on the centrifugal fan.**

## 9.3. Checks after Running-In phase

After a running-in phase of 1 to 2 hours the following checks have to be made:

- Centrifugal fan secured against involuntary switching on!
1. Check belt tension and retighten if necessary.  
(see chapter 10.5.1 / 10.5.2 / 10.5.3)
  2. Check bearing temperature (see attachment)

# 10. Maintenance

## 10.1. Safety Instructions for Maintenance

- ▶ Observe the safety instructions and preventive measures in Chapter 4 and the relevant legal requirements.
- ▶ Follow the directions of the motor supplier and the instructions specified by the manufacturers of the switches and control units.



**Warning**

**Works on the fan are authorised only when fully cut off power supply!**

**Caution**

**Pressure washers can cause damage to property!**

Do not use pressure washers (steam jet cleaners) to clean the equipment.

**Caution**

**Unsealed sleeving leads to breakdowns and danger from escaping transported medium and must be replaced.**

## 10.2. Observing Regular Inspection Intervals

In the interests of upkeep and safety we recommend having the operation and condition of the fans inspected at regular intervals by duly qualified service personnel or a professional maintenance firm and documenting these inspections.

The nature and extent of the maintenance work, the service intervals and any additional work required needs to be specified on a case-by-case basis depending on the use of the fans and the general conditions on site.

Our servicing and inspection recommendations based on VDMA 24186-1 can be found on our website.

## 10.3. Preparing for Maintenance

1. Disconnect the motor from the mains.
2. Centrifugal fans fitted with an inspection switch should be switched off using the inspection switch.
3. Take measures to prevent the centrifugal fan from being switched on accidentally.
4. Wait until the impeller has stopped.
5. Wait until all hot surfaces have cooled down.
6. Remove any residues from the fan.
7. Depending on the situation installation components may be dismantled for inspection and maintenance.

**Preparation for maintenance is completed**

## 10.4 Maintenance recommendations for centrifugal fans:

Table 10-1:

Maint. recommendation

- ▶ Conduct test run if applicable (see Chapter 8.4).
- ▶ Document inspection intervals observed.

Pos.	Description	quarterly	cyclic	on demand
<b>1.0</b>	<b>Fan</b>			
1.1	Check deposit, damages, corrosion an fixing	x		
1.2	Check impeller for damage and unbalancing, vibration check	x		
1.3	Check bearing noise	x		
1.4	Relubricate bearing (acc. to relubrication plan)		x	
1.5	Check flexible connection for tightness	x		
1.6	Check correct function of AVM	x		
1.7	Check safety devices (guards) for effectivity	x		
1.8	Check condense water drain	x		
1.9	Clean whole unit in order to keep all elements in best working conditions	x		x
1.10	Check rotational sense of impeller (for all speeds)	x		
1.11	Check fan function and its readiness to immediate start up		x	
<b>2.0</b>	<b>Motor</b>			
2.1	Visual control for dirt, damages, corrosion and correct fixing	x		x
2.2	Check rotational sense	x		
2.3	Check bearing noise	x		
2.4	Relubricate bearing (in case of relubricatable bearings)		x	
2.5	Check safety devices (guards) for effectivity	x		
2.6	Check tight electrical connections on tight fixing	x		
2.7	Clean whole unit in order to keep all elements in best working conditions	x		x
<b>3.0</b>	<b>Belt Drive</b>			
3.1	Check for deposit, damages and wear	x		
3.2	Change V-belts			x
3.3	Check tightening and alignment	x		
3.4	If necessary retighten / align			x
3.5	Check safety devices (guards) for effectivity	x		

**10.4.1 Vibration monitoring**

The fan has to be frequently checked for vibrations. The max. vibration velocity values admitted are those which relate to ISO 14694.

Table 10-2:  
Vibration velocity

Size	Vibration velocities mm/s
≤ 0315	7,1
≥ 0355	4,5

These vibration velocities are to be measured in a radial direction on the bearing or bearing casing of the motor.

Deposits of dirt and dust on the impeller can cause unbalancing and subsequent damages. In order to prevent this danger frequent inspections and cleaning measures have to be carried out depending on the degree of possible deposit.

**10.4.2 Motor bearings**

The motor bearings are supplied permanently lubricated by the factory; experience has shown that the grease needs to be changed only after several years only under normal operating conditions.

In the case of bearing noise please contact Nicotra Gebhardt-Service for a check and a possible change of defective bearings.

**10.4.3 Periods of stand still**

During longer periods of standstill the fan must from time to time be put into operation for a short while. This is to avoid bearing damages due to the mechanical load and ingress of humidity.

After longer periods of storage, the fan and motor bearings have to be checked prior to installation.

**10.5. Belt drive**

The belt drive has to reply to the requirements of the ATEX guideline and will maintenance free be after the start-up / running-in phase.

It is nevertheless recommended to check belt tension in regular intervals.

The test force  $F_p$  is indicated at the type plate and the design sheet.

### 10.5.1 Tensioning rules for V-belt drives

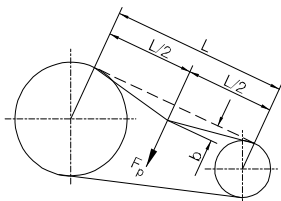

Fig. 10-3: V-belt drive

$L$  = Span between shaft centres  
 $b$  = Belt deflection under test force  $F_p$   
 $F_p$  = Test force in N from the

- ▶ The correct tensioning for a belt is achieved if the individual test force  $F_p$  produces a belt deflection  $b$  of 16 mm per 1000 mm of span.

### 10.5.2 Tensioning rules for flat belts

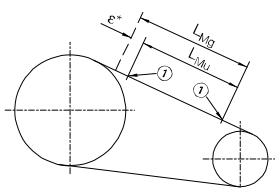

Fig. 10-4: Flat belt drive

$L_{Mu}$  = Measurement mark spacing on un-tensioned flat belt  
 $L_{Mg}$  = Measurement mark spacing on correctly tensioned belt  
 $\epsilon^*$  = Increase in mm from the manufacturer documentation

- ▶ The correct belt tensioning has been achieved when the measurement mark spacing  $L_{Mu}$  has increased by  $\epsilon^*$ . The adjustment should take place in two stages with a time period of some hours in between to avoid overloading the bearings.

### 10.5.3 Tensioning rules for V-belt and flat belt drive

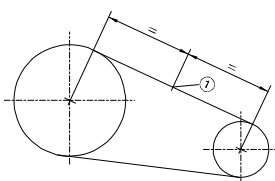

Fig. 10-5: Belt drive

The check of the belt tension is made through observation of the static belt frequency. For this purpose the flat or V-belt is hit and vibrating at resonance frequency. An electronically measuring device - the so-called Trummeter – will relate this to the tension force. The oscillation in Hz has to correspond to the value indicated in the documentation/type plate.

**The measuring point is places in the centre (1) of the belt, i.e. between both pulleys.**

### 10.5.4 Belt changing

- ▶ The centre distance should be reduced until the new belt/s can be easily fitted by hand.
- ▶ The tensioning of the belt follows in accordance to the respective tensioning rules.  
Observe the running-in phase!

### 10.5.5 Pulley changing

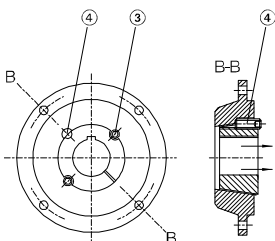

To release the pulley wheel:

1. Unscrew the bolts (3).
2. Tighten the socket head cap screw in the threaded hole (4).
3. Press the clamping bush out of the tapered hole.
4. The pulley wheel can now be easily slid of the shaft.

*Fig. 10-6 to release:*

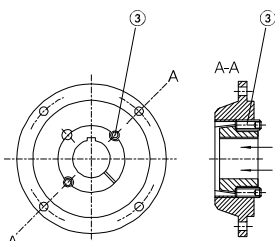

To fix the pulley :

1. Pull the pulley wheel and the clamping bush together by means of the socket head cap screw (3).
2. Motor pulley and fan pulley to be exactly in line
3. Belt tension to be set according to instructions

*Fig. 10-7: Fixing*



---

**Note** Ensure that the motor pulley and the fan drive pulley are accurately aligned.  
Fit and tension the belt in accordance with instructions.

---

#### 10.5.6 Belt drive design

If the belt drive is designed or modified without using the Nicotra Gebhardt selection programme the speed limits of the fan as well as the limitations for belt forces

- to be found in the corresponding catalogue - are to be respected.

Only electro statically conductive belts acc. to ATEX guideline may be used.

---

#### 10.5.7 Drive guard

Belt guard must be designed in accordance with EN 14986!

---

#### 10.6. Fan bearings

The fan bearings are "Life span" lubricated as standard. However in heavy duty operational conditions maintenance intervals are to be established by the operator. Our maintenance guidelines on later lubrication are to be observed.

---

#### 10.7. Flexible connections

Flexible connections (compensators) between fan and ducting have to reply to ATEX requirements. They are to be checked in regular intervals.

---

**Caution** If the state of the fan does not allow adapted action for repair it has to be put out of order immediately and to be replaced if required.

---

## 11. Disturbances

If disturbances occur during operation which cannot be repaired by maintenance personnel please contact the service department of Nicotra Gebhardt GmbH.

---



Warning

#### Risk of explosion caused by improper operating states!

- ▶ Switch the fan off immediately if permissible limits are exceeded and in the event of irregularities or faults.

## 12. Service, Spare Parts and Accessories

Nicotra Gebhardt GmbH  
 Gebhardtstraße 19–25  
 74638 Waldenburg  
 Germany

Telephone: +49 (0) 7942 101 384  
 Fax: +49 (0) 7942 101 385  
 E-mail: [info@nicotra-gebhardt.com](mailto:info@nicotra-gebhardt.com)  
[www.nicotra-gebhardt.com](http://www.nicotra-gebhardt.com)

### 12.1. Ordering Spare Parts

- ▶ Use only genuine spare parts supplied by Nicotra Gebhardt GmbH as featured in the list of spare parts.

The use of spare parts supplied by other manufacturers may compromise the safety of the equipment. Nicotra Gebhardt GmbH shall not accept any liability or provide any warranty cover in respect of primary or secondary damage arising as a consequence of using spare parts supplied by other manufacturers.

Spare parts can be ordered online at -- [www.nicotra-gebhardt.com/Partshop](http://www.nicotra-gebhardt.com/Partshop)

### 12.2. Accessories

Nicotra Gebhardt GmbH has a wide range of accessories for the economical and efficient use of its fans.

Accessories are optional and always need to be ordered separately.

Spare parts should be selected on the basis of the technical specifications or via our electronic selection program. Accessories are supplied with separate operating or installation instructions unless their installation or uses are self-explanatory.

## 13. Annex

### 13.1 Further Documentation Supplied by Nicotra Gebhardt GmbH

*Table 13 1: Further documentation*

Type of Documentation	File Location
Maintenance and inspection recommendations	Internet
Bearing maintenance	Annex
EU-Declaration of Conformity	Annex
EC-Declaration of Incorporation	Annex

### 13.2 Annex - Bearing Maintenance

**Note** or service and maintenance observe the following instructions

- **Safety instructions** Chapter 4
- **Service/ Maintenance** Chapter 10
- **Safety Notes** Chapter 10.1

**Note** As a standard there are only noise tested precision bearings fitted, designed for a nominal life time (L10h acc. to ISO 281-1) of 20 000 operation hours. In order to not exceed the permitted bearing loads there are minimum pulley diameters specified for each fan whose values must be fallen below. The minimum pulley diameter indicated are applicable for belt drives which are correctly dimensioned to the actual „state of the art“ and tighten to the tightening specification.

For flat belt drives the minimum pulley diameter value has to be increased of about 40%!

### 13.2.1 Bearings without Lubricating Device

The bearings are normally supplied greased for life with a high-performance grease that is resistant to ageing and does not require maintenance under normal operating conditions.

If in the case of normal wear and tear a bearing change is required ask for the Nicotra Gebhardt-Service.

### 13.2.2 Bearings with Lubricating Device

IWN 01 – Stand grease

IWN 11 – Moisture resistant grease

IWN 21 – High temperature grease (RER)

---

**Caution** In order to reach the maximum permitted bearing lifetime under heavy duty operating conditions, they have to reduplicate within regular intervals.

The intervals depend on the specific operating conditions and are to be determined by the operator. The maintenance instructions of the fans containing republication guidelines have to be taken into account.

---

### 13.2.3 Relubrication intervals

Under normal operating conditions a relubrication has to be carried out at least once a year!

This is applicable for bearings of a shaft in a horizontal position and when the temperature at outer bearing ring does not exceed +70°C.

- **For temperatures exceeding +70°C the relubrication interval has to reduce to half for every 15°C above this value.**

---

### 13.2.4 Relubrication with Lubricating Device

Relubrication during operation (only applicable for RZR fans) is carried out by pressing the required quantity of grease through the (by tubes extended) conical grease nipple into the bearing.

The escaped old grease has to be taken off during a short stop of the fan.

**For self aligning bearings fitted in a split plummer block casing a cleaning of the bearing and a fully new greasing has to be carried out!**

RZR 11- 0200-/.0710  
 RZR 12- 0200-/.0710  
 RZR 19- 0200-/.0355

**Cast iron housing with struts and self aligning radial insert ball bearings**  
 with lubrication device **IWN**

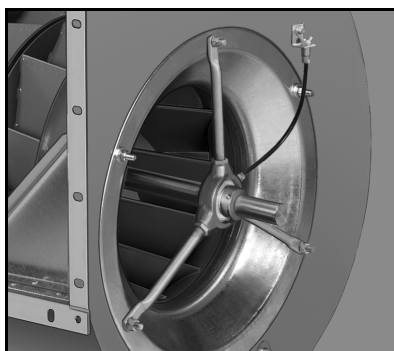

*Fig. 13-5: Ball bearings in cast iron housing with struts*

Relubrication at least once a year.  
 Interval to be reduced for heavy duty operation

Grease Quantity:  
 Press grease into bearing until fresh grease is escaping.

RZR 15-0400-/.1000  
 RZR 19-0400-/.1000

**Split type cast iron housing strut mounted with self-aligning double row bearings,**  
 with lubrication device **IWN**



*Fig. 13-6: Self aligning double row bearing in a cast iron housing*

Relubrication at least once a year.  
 Interval to be reduced for heavy duty operation

*Table 13-4: Grease quantity*

RZR 15 / 19- Grease quantity	0400-0500	0560-0630	0710-0800	0900-1000
	15 g	20 g	30 g	35 g

RZR 13-0400-/.1000  
 RZR 18-0400-/.1000  
 RZR 13-1120-/.1600

**Split type plummer block housing with self-aligning double row bearings**  
 with lubrication device **IWN**

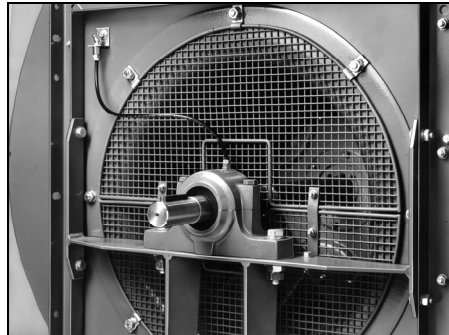

*Fig. 13-4: Self aligning double row bearing in a Plummer block housing*

Relubrication at least once a year.  
 Interval to be reduced for heavy duty operation

<b>RZR 13 / 18-</b>	<b>0400-0500</b>	<b>0560-0630</b>	<b>0710-0800</b>	<b>0900-1000</b>
Grease quantity	15 g	20 g	30 g	35 g
<b>RZR 13-</b>	<b>1120</b>	<b>1250</b>	<b>1400</b>	<b>1600</b>
Grease quantity	35 g	40 g	50g	50g

*Table 13-5: Grease quantity*

RER 13-0200-/.1000;  
 RER 17-0200-/.1000;

**Split type Plummer block housing with self-aligning double row bearings**  
 with lubrication device **IWN**

0200 /-1000

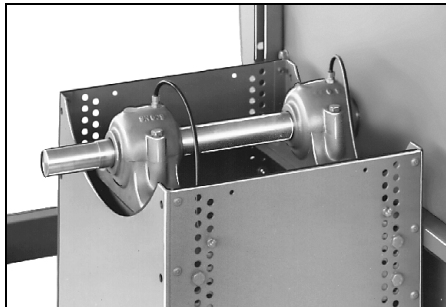

*Fig. 13-5: Self aligning double row bearing in a Plummer block housing*

Relubrication at least once a year.  
 Interval to be reduced for heavy duty operation

<b>RER 13-/17-</b>	<b>0200-0250</b>	<b>0280-0355</b>	<b>0400-0500</b>	<b>0560-0710</b>	<b>0800-1000</b>
Grease quantity	15 g	15 g	25 g	30 g	35 g

*Table 13-6: Grease quantity*

## EU Declaration of Conformity to EU Council Directive 2014/34/EU (ATEX)

Der Hersteller:

**Nicotra Gebhardt GmbH**

Gebhardtstraße 19-25, 74638 Waldenburg, Germany

herewith declares, that the machinery designated below, on the basis of its design and construction in the form brought onto the market by us is in accordance with the relevant safety and health requirements of the EU Council Directive as mentioned below. If any alterations are made to the machinery without prior consultations with us this shall render the declaration invalid.

Designation:

**Centrifugal fan with housing, categories 2G or 3G for conveying explosive atmosphere**

Machine type:

**RZR / RER .. -2G; RZR / RER .. -3G**

Category:

**II 2G c IIB T3; II 3G c IIB T3**

Year of Production/Type:

See type plate

Relevant EU Council Directive:

**EU Directive 2014/34/EU (ATEX)**

Applied harmonized standards<sup>1)</sup>, in particular:

**EN 13463-1, EN 13463-5, EN 1127-1, EN 14986**

Name of Notified Body:

TÜV SÜD Produkt Service; Zertifizierstelle; Riedelstraße 65; 80339 München; Germany

EC-certificate number:

EX9 11 09 78300 005

It is the responsibility of the manufacturer or contractor to ensure that conformity to these standards is observed when installing the fan in a machine or system.

The manufacturer is solely responsible for issuing the declaration of conformity.

Waldenburg, 29.10.2015

Head of Production



i.V. T. Ehrhardt

Research and Development Director



i.V. Dr. J. Anschütz

<sup>1)</sup>For the complete list of applied standards and technical specifications please see the manufacturer's documentation.

## EC-Declaration of Incorporation

The manufacturer: Nicotra Gebhardt GmbH, Gebhardtstraße 19-25,  
74638 Waldenburg, Germany

herewith declares, that the following product:

Product designation: Centrifugal fan  
Type nomination: **RZR / RER .. -2G; RZR / RER .. -3G**  
Serial n°: see type plate  
Year of manufacture: see type plate

qualifies as a partly completed machine, according to Article 2, clause “g” and complies with the following basic requirements of the Machine Directive (2006/42/EC): Annex I, Article 1.1.2; 1.3.7

The partly completed machine may be put into operation only if it has been stated that the machine into which the uncompleted machine has to be incorporated complies with the requirements of the Machine Directive (2006/42/EC).

The following harmonised standards<sup>1)</sup> have been applied:

**EN ISO 12100** Safety of machines – Fundamental terms, general design principles

**EN ISO 13857** Safety of machines – Safety distances to hazardous areas

The manufacturer is committed to providing the special documents to Annex VII, Part B, for partly completed machines to any state authority per post/email on request.

Waldenburg, 29.10.2015

Representative for the documentation: Michael Hampel

Head of Production



i.V. T. Ehrhardt

Research and Development Director



i.V. Dr. J. Anschütz

<sup>1)</sup>For the complete list of applied standards and technical specifications please see the manufacturer's documentation.

**NICOTRA||Gebhardt** Nicotra Gebhardt GmbH  
fan|tastic solutions Gebhardtstraße 19-25  
74638 Waldenburg  
Germany

Telefon +49 (0)7942 1010  
Telefax +49 (0)7942 101170  
E-Mail [info@nicotra-gebhardt.com](mailto:info@nicotra-gebhardt.com)

[www.nicotra-gebhardt.com](http://www.nicotra-gebhardt.com)