

LPKB 315 F1 EC

ÖSTBERG

- Low profile duct fan with circular connections.
- A small and useful duct fan which are perfect for spaces with minimum height clearance.
- With one connection on the inlet side.
- High capacity and efficiency with low sound levels.
- Impeller with backward curved blades.
- The external rotor motor has maintenance-free sealed ball-bearings and is very energy efficient.
- Speed controlling can be done with the built-in potentiometer, 0-10 V alt. external control.
- Integrated motor protection.
- Junction box has enclosure class IP 54.
- Fan housing is manufactured from galvanized sheet steel.
- Duct connections are equipped with rubber seals.
- The fan is intended to be installed in a duct system.
- A duct connected fan can be installed outside or in damp environments.
- The mounting brackets simplify installation in any position.

Accessories

- Speed controller MS EC
- Controller IQ-Reg EC
- Pressure regulator CALAIR-PR-230V
- Pressure regulator FKP-R
- MK 315
- FLK 315
- FLF 315
- BSV 315
- RSK 315
- YG 315
- VK 315
- LDC 315

7540832
LPKB 315 F1 EC-y1
TECHNICAL DATA

Voltage	230 V
Phase	1 ~
Frequency	50/60 Hz
Power	319 W
Current	2.45 A
Speed	2890 r.p.m.
Max. temperature of transported air	60 °C
Sound pressure level at 3 m	55 dB(A)
Weight	14.8 kg
Enclosure class	44 IP
Insulation class, motor	F
Duct connection	315 mm
Max. flow @ 0Pa	1940.4054331352 m³/h
Max. pressure	937 Pa
Voltage range	200-277 V

SOUND DATA

	Flow (m³/h)	L _{WA} tot dB (A)	63Hz	125Hz	250Hz	500Hz	1KHz	2KHz	4KHz	8KHz
5. Surrounding Lw dB(A) 10V	1166	62	36	50	55	57	55	52	47	41
5. Outlet Lw dB(A) 10V	1166	83	66	66	71	79	74	78	73	69
5. Inlet Lw dB(A) 10V	1166	79	66	65	69	71	71	72	70	66
4. Inlet Lw dB(A) 8V	1048	77	63	62	68	71	69	70	68	64
3. Inlet Lw dB(A) 6V	814	71	56	57	64	64	63	63	61	55
2. Inlet Lw dB(A) 4V	551	62	48	49	59	53	53	53	50	41
1. Inlet Lw dB(A) 2V	284	45	35	38	40	38	34	32	24	14

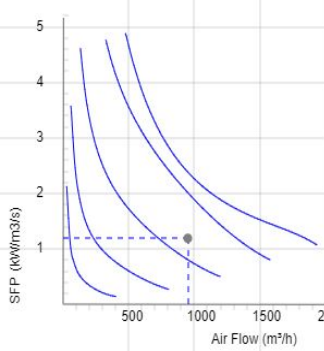
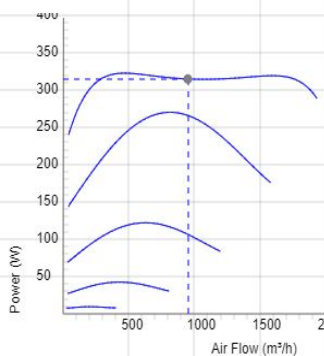
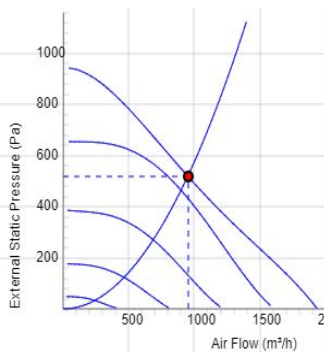
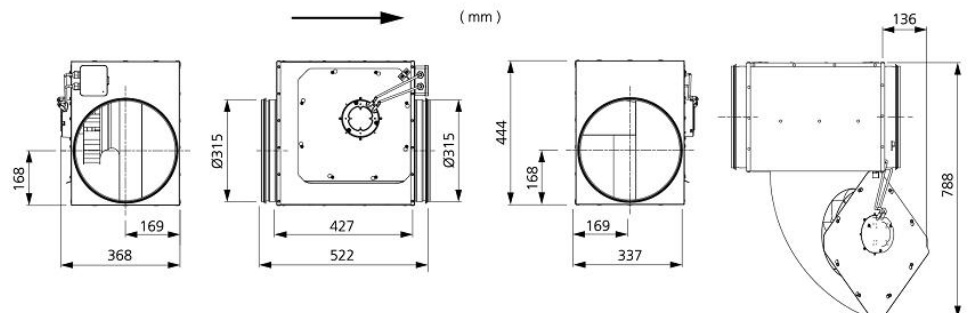
DIMENSIONS

Voltage steps

1	2	3	4	5
2V	4V	6V	8V	10V